

Holding & Display Cabinets

*Cafeterias • Convenience Stores
Catering • Concessions*



PWC-12 in optional *Designer Black* pg. 183



FSDT-2X with accessory 4-shelf multi-purpose rack, and optional sign holder (sign not included) pg. 185



IHDC-45 with accessory risers and sign holders pg. 189



MDW-1X with optional *Designer Black* and hood with backlit sign cut out on one side (sign included) pg. 193



FST-1-MN shown in standard Bronze pg. 194



FSHC-7W1-EE shown in *Designer Black*, with optional bumper kit, and right-hand hinged door pg. 196



FSHC-17W1 with accessory food pans pg. 199



FSHC-2PT Pass-through with accessory food pans pg. 201



FS2HAC-15 With third-size food pans (pans not included) pg. 201

Plate Warmers

Hatco's Plate Warmers are designed to hold preheated serving plates where your customers can access them easily. Countertop or Built-In models available. Easy to load and easy to clean. Serving hot food on preheated plates will help extend the holding times of most foods, and adds to a better customer experience.

- Can hold 25 plates up to 12" in diameter
- A covered, digital temperature control with an adjustable range of 104° - 122°F
- Energy efficient LED lighting illuminates the interior from the top
- Available in Stainless Steel or *Designer Black* powdercoating
- Cabinet cutout dimensions are: 16 $\frac{5}{8}$ " x 20 $\frac{1}{8}$ "



PWB-12
in standard
Stainless Steel



PWC-12
in optional *Designer Black*

Holding &
Display Cabinets

PLATE WARMERS

Model	Item Number	Description	Dimensions (W x D x H ‡)	Opening Dimensions (W x H)	Voltage	Watts	Amps	Approx. Ship Weight
Countertop								
PWC-12	PWC.12SS515	Countertop, Stainless Steel	16 $\frac{7}{8}$ " x 17 $\frac{3}{8}$ " x 22 $\frac{3}{8}$ "	12 $\frac{5}{8}$ " x 15 $\frac{3}{4}$ "	120	460	3.8	64 lbs.
Built-In								
PWB-12	PWB.12SS515	Built-In, Stainless Steel	17 $\frac{1}{2}$ " x 17 $\frac{1}{2}$ " x 21 $\frac{1}{8}$ "	12 $\frac{3}{4}$ " x 15 $\frac{3}{4}$ "	120	460	3.8	49 lbs.

‡ Height includes standard 1" legs.

All Plate Warmer Models Feature:

Models Shipped with:

PWC-12: Power On/Off switch, a detachable 6' power cord, a 3' jumper cord and a wall-mounting kit, NEMA 5-15P plug.

PWB-12: Power On/Off switch, a detachable 6' power cord and a 3' jumper cord, NEMA 5-15P plug.

Cabinet cut-out dimensions for PWB-12: 16 $\frac{5}{8}$ " W x 20 $\frac{1}{4}$ " H.

Cord Location: back of unit, top left corner.

OPTIONS (available at time of purchase only)

Designer Color – Non-standard colors are non-returnable – Stainless Steel Standard – BLACK *Designer Black*

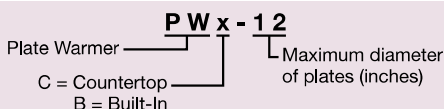

Flav-R-Fresh® Humidified Impulse Display Cabinets

A profitable way to create impulse food sales is with the small Flav-R-Fresh® Holding and Display Cabinet. Using controlled moisturized heat allows you to showcase your product longer using minimum counter space.

- Full-view display with tempered glass sides and door
- Controlled heat and humidity for longer holding times
- Accommodates half-size sheet pans
- Revolving or stationary display racks
- Single- or reversible double-sided opening models
- LED lights illuminate the holding areas and emphasize the product



FDWD-2 with accessory 4-tier circle rack

IMPULSE CABINETS

Model*	Description*	Dimensions W x D x H †	Cabinet Opening W x H	Voltage Single Phase	Watts	Approx. Ship Weight
FDWD-1	1 Door w/4-Tier Circle Rack w/Motor	19 3/8" x 20 7/8" x 28 7/8"	15 3/4" x 19 3/4"	120	1360	90 lbs.
FDWD-1X	1 Door w/4-Shelf Multi-Purpose Rack w/o Motor	19 3/8" x 20 7/8" x 28 7/8"	15 3/4" x 19 3/4"	120	1360	90 lbs.
FDWD-2	2 Doors w/4-Tier Circle Rack w/Motor	19 3/8" x 22" x 28 7/8"	15 3/4" x 19 3/4"	120	1360	90 lbs.
FDWD-2X	2 Doors w/4-Shelf Multi-Purpose Rack w/o Motor	19 3/8" x 22" x 28 7/8"	15 3/4" x 19 3/4"	120	1360	90 lbs.

- ♦ Models FDWD-1 and FDWD-2 include rack motor. Models with "X" designator do not have revolving display and are NOT available for retrofit.
- † Rack listed is included with unit. Other racks available.
- ‡ Height includes standard 1" legs.
- * For non-humidified cabinet, unit will only operate in dry mode.

All Impulse Cabinet Models Feature:

Voltage: 60 Hz, 11.3 amps, NEMA 5-15P plug.

Door Hinges – Control Side and Customer Side (two-door models only): Left-hand side.

Max. Pizza Size: 15" diameter with 4-Tier Circle Rack.

Water Tank Capacity for Humidity System: 1/2 gallon.

Cord Location: Facing controls, left-hand side panel, lower right corner.

WATER QUALITY REQUIREMENTS – PAGE 247

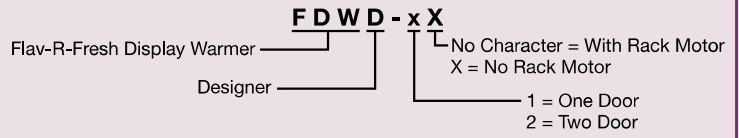

OPTIONS (available at time of purchase only)

Designer Colors – Non-standard colors are non-returnable – Clear Anodized Aluminum Standard –

RED	Warm Red
BLACK	Black
GRAY	Gray Granite
WHITE	White Granite
NAVY	Navy Blue
GREEN	Hunter Green
COPPER	Antique Copper
LED-NW18	Neutral White (cool) LED lighting (in lieu of standard Warm White)
FDWD-SCD	Self Closing Door in lieu of standard door (left hinge only). Must upgrade both doors on FDWD-2, -2X (not field reversible)
FDWD-6FRT	6" Merchandising Display Sign Holder for Control Side only (Includes metal holder only). Available in all Designer Colors to match your unit (Black is standard). Adds 1 1/8" to height of unit. Requires (1) sign 19 3/16"W x 6 3/16"H x 1/16"D – not included
FDWD-DIS	3" One Sided Merchandising Display Sign Holder (includes metal holder and window) – one per side, three maximum. Available in all Designer Colors to match your unit (Black is standard). Adds 1 1/4" to height of unit. Requires (1) sign 19 1/16"W x 3 1/4"H x 1/16"D – not included
FDWD-6SIGN	6 3/8" One-Sided Merchandising Display Sign Holder (includes metal holder and window) – one per side, three maximum. Available in all Designer Colors to match your unit (Black is standard). Adds 1 1/4" to height of unit. Requires (1) sign 19 3/16"W x 6 1/4"H x 1/16"D – not included

ACCESSORIES (available for purchase at any time)

FDWD-LEGS	4" Adjustable Legs (4"-5")
COUPLING	Motorless Rack Coupling for FDWD-1X and FDWD-2X models (select Circle Rack or Pretzel Tree)
FDWD4TCRR	4-Tier Circle Rack with Pizza Pan Retainers (Requires Coupling for -1X or -2X models)
FDWD4SMP	4-Shelf Multi-Purpose Rack (each shelf 13 5/8"W x 12 5/8"D)
FDWD3TPT	3-Tier Pretzel Tree (requires Coupling for -1X or -2X models)

DECORATIVE KIT – PAGE 187

RACKS – PAGE 188

FOOD PANS AND TRIVETS – PAGE 245

COLORS AND FINISHES – INSIDE BACK COVER



COUPLING
Accessory



Flav-R-Savor® Humidified Holding & Display Cabinets

Balancing a precise combination of heat and humidity, the Hatco Flav-R-Savor® Cabinets provide an attractive showcase for hot food displays and generate impulse sales. A complete range of cabinet sizes, door options and rack types allows for perfect merchandising of food products such as pizza, fried foods, bakery items, sandwiches and more.

- Full-view display with tempered glass sides and door provide maximum heat retention
- Controlled heat and humidity for longer holding times
- ¾ gallon stainless water reservoir provides all day moisture
- Low-water protection prevents heating element burnout and alerts operator to low-water condition
- Revolving or stationary display racks
- Available in two heights with single-sided or double-sided openings
- Energy efficient LED lighting to illuminate your food display



FSD-1 with 3-tier pan rack and accessory food pans



FSDT-2 with 4-tier circle rack and 4" legs, optional Designer Black color and accessory food pans

DISPLAY CABINETS

Model	Description	Dimensions W x D x H	Approx. Ship Weight
Standard			
FSD-1	1 Door w/3-Tier Circle Rack w/Motor	22½" x 24½" x 27¾"	129 lbs.
FSD-1X	1 Door w/3-Tier Pan Rack w/o Motor	22½" x 24½" x 27¾"	126 lbs.
FSD-2	2 Doors w/3-Tier Circle Rack w/Motor	22½" x 25¾" x 27¾"	126 lbs.
FSD-2X	2 Doors w/3-Tier Pan Rack w/o Motor	22½" x 25¾" x 27¾"	126 lbs.
Tall			
FSDT-1	1 Door w/4-Tier Circle Rack w/Motor	22½" x 24½" x 32½"	128 lbs.
FSDT-1X	1 Door w/4-Tier Pan Rack w/o Motor	22½" x 24½" x 32½"	126 lbs.
FSDT-2	2 Doors w/4-Tier Circle Rack w/Motor	22½" x 25¾" x 32½"	126 lbs.
FSDT-2X	2 Doors w/4-Tier Pan Rack w/o Motor	22½" x 25¾" x 32½"	126 lbs.

- ♦ Models FSD-1, FSD-2, FSDT-1 and FSDT-2 include rack motor. Models with "X" designator do not have revolving display and are NOT available for retrofit.
- ‡ Rack listed is included with unit. Other racks available.
- * For non-humidified cabinet, unit will only operate in dry mode.

All Display Cabinet Models Feature:

Voltage: 120, single phase, 60 Hz, 1414 watts, 11.8 amps, NEMA 5-15P plug.

Cabinet Opening Dimensions: Standard Models: 19"W x 18½"H.

Tall Models: 19"W x 23¾"H.

Door Hinges: Control Side: Left-hand side.

Customer Side (two-door models only): Right-hand side.

Max. Pan Size: 19" diameter with 4-Tier Circle Rack.

Water Tank Capacity for Humidity System: ¾ gallon.

Cord Location: Facing controls, left-hand side panel, lower right corner.

OPTIONS AND ACCESSORIES – PAGE 186

DECORATIVE KIT – PAGE 187

RACKS – PAGE 188

FOOD PANS AND TRIVETS – PAGE 245

WATER QUALITY REQUIREMENTS – PAGE 247

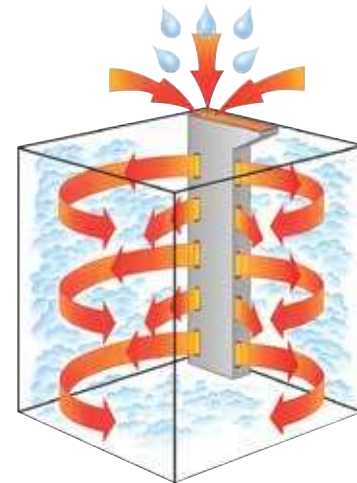

CONTROLLED MOISTURIZED HEAT KEEPS HOT FOODS FRESH LONGER Hatco's Flav-R-Savor® air flow pattern is designed to maintain consistent cabinet temperature without drying out foods. The precise combination of heat and humidity creates a "blanket" effect around the food. The air flow rate enables the cabinet to recover temperature rapidly after opening and closing the door.

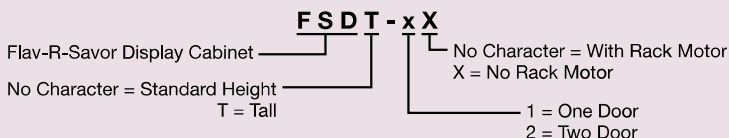

Holding &
Display Cabinets



Two FSDT-1 with 4-tier circle racks, optional sign holders (signs not included) and accessory food pans

OPTIONS (available at time of purchase only)

LED-NW18	Neutral White (cool) LED lighting (in lieu of standard Neutral White)
THERM	Mechanical Controls
FSD7SIGN	7½" Merchandising Display Sign Holder (includes metal holder and window) – one per side , three maximum. Available in all <i>Designer</i> Colors to match your unit (Black is standard). Adds 1¼" to height of unit. Requires (1) sign 22½"W x 7½"H x 1/16"D – not included

ACCESSORIES (available for purchase at any time)

F-LEGS-4	4" Adjustable Legs
COUPLING	Motorless Rack Coupling for FSD-1X, FSD-2X, FSDT-1X and FSDT-2X models (select appropriate Circle Rack or Pretzel Tree)

RACKS – FSD ONLY –

FSD5SMP	5-Shelf Multi-Purpose Rack (each shelf - 18"W x 16"D)
FSD3TCR	3-Tier Circle Rack with Pizza Pan Retainers (requires Coupling for -1X or -2X models)
FSD3TPR	3-Tier Pan Rack (accommodates Half-Size Sheet Pans, not included)

RACKS – FSDT ONLY –

FSDT7SMP	7-Shelf Multi-Purpose Rack (each shelf - 18"W x 16"D)
FSDT4TCR	4-Tier Circle Rack with Pizza Pan Retainers (requires Coupling for -1X or -2X models)
FSDT5TCR	5-Tier Circle Rack with Pizza Pan Retainers (requires Coupling for -1X or -2X models)
FSDT4TPR	4-Tier Pan Rack (accommodates Half-Size Sheet Pans, not included)
FSDT3SAR	3-Shelf Angle Rack (15° angle shelves) (each shelf - 18"W x 16¼"D)
FSDT3TPT	3-Tier Pretzel Tree (requires Coupling for -1X or -2X models)

DECORATIVE KIT – PAGE 187

RACKS – PAGE 188

FOOD PANS AND TRIVETS – PAGE 245

COLORS AND FINISHES – INSIDE BACK COVER

OPTIONS (available at time of purchase only)

Designer Colors

– **Non-standard colors are non-returnable**

– **Clear Anodized Aluminum Standard –**

RED	Warm Red
BLACK	Black
GRAY	Gray Granite
WHITE	White Granite
NAVY	Navy Blue
GREEN	Hunter Green
COPPER	Antique Copper

Decorative Kit for FDWD, FSD, FSDT models only

Transform your Hatco Flav-R-Savor® Holding & Display Cabinet from a "heated box" into a *Designer Merchandiser* with a variety of simple accessory additions. Create a new look and feel to your decór.

- The curved hinged header allows easy access to controls and water fill cup, and gives a great area to brand your food product with a magnetic sign (sign not included)
- The base skirt completes the transformation and gives an additional branding area. Available in flat or curved panels for front and/or back of unit
- Signs can be decals or magnetic
- Signs not included

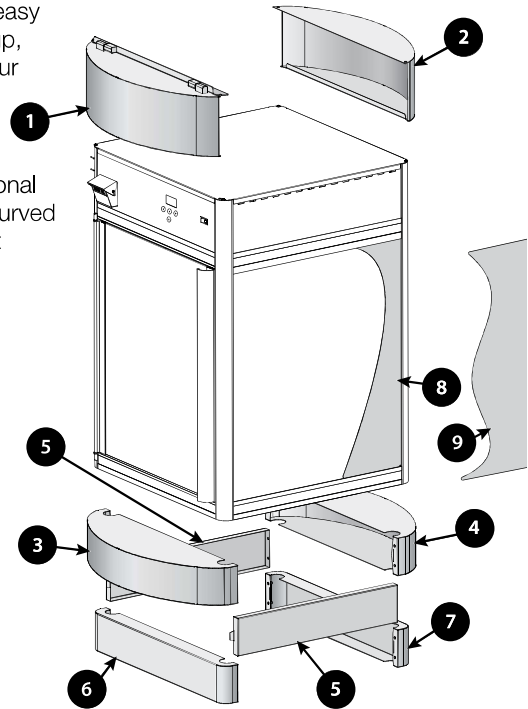

OPTIONS (available at time of purchase only) (additional lead time required)

Designer Colors – Non-standard colors are non-returnable – Black Standard –

RED	WR	Warm Red
GRAY	GG	Gray Granite
WHITE	WG	White Granite
NAVY	NB	Navy Blue
GREEN	HG	Hunter Green
COPPER	AC	Antique Copper

ACCESSORIES (available for purchase at any time)

Side Insets – Must choose Designer Color – Black Standard –

FSD-INSET1 ③	Two Crescent Inset Panels for FSD models
FSD-INSET2 ④	Two Wave Inset Panels for FSD models
FSDT-INSET1 ③	Two Crescent Inset Panels for FSDT models
FSDT-INSET2 ④	Two Wave Inset Panels for FSDT models
FDWD-INSET1 ③	Two Crescent Inset Panels for FDWD models
FDWD-INSET2 ④	Two Wave Inset Panels for FDWD models

Top Covers – Must choose Designer Color – Black Standard – Signs not Included –

FSD-CTLH ①	Curved Hinged Header on control side (Fits 24"W x 5 ⁵ / ₈ "H sign) for FSD and FSDT models
FDWD-CTLH ①	Curved Hinged Header on control side (Fits 20 ¹ / ₂ "W x 4 ⁷ / ₈ "H sign) for FDWD models
FSD-CUSH ②	Curved Header on non-control side (Fits 24"W x 5 ⁵ / ₈ "H sign) for FSD and FSDT models
FDWD-CUSH ②	Curved Header on non-control side (Fits 20 ¹ / ₂ "W x 4 ⁷ / ₈ "H sign) for FDWD models

Base Skirts – Requires 4" adjustable legs (not included) – Must choose Designer Color – Black Standard – Signs not Included –

FSD-SQB	One Flat Front Panel ⑥ and one Flat Back Panel ⑦ (Fits 20"W x 3 ³ / ₄ "H sign) and two Flat Side Panels ⑤ (Fits 18 ³ / ₈ "W x 3 ³ / ₄ "H sign) for FSD and FSDT models
FDWD-SQB	One Flat Front Panel ⑥ and one Flat Back Panel ⑦ (Fits 17 ¹ / ₄ "W x 3 ³ / ₄ "H sign) and two Flat Side Panels ⑤ (Fits 15 ¹ / ₂ "W x 3 ³ / ₄ "H sign) for FDWD models
FSD-1CB	One Curved Front Panel ③ and one Flat Back Panel ⑦ (Fits 25 ¹ / ₂ "W x 3 ³ / ₄ "H sign) and two Flat Side Panels ⑤ (Fits 18 ³ / ₈ "W x 3 ³ / ₄ "H sign) for FSD and FSDT models
FDWD-1CB	One Curved Front Panel ③ and one Flat Back Panel ⑦ (Fits 22 ¹ / ₄ "W x 3 ³ / ₄ "H sign) and two Flat Side Panels ⑤ (Fits 15 ¹ / ₂ "W x 3 ³ / ₄ "H sign) for FDWD models
FSD-2CB	One Curved Front Panel ③ and one Curved Back Panel ④ (Fits 25 ¹ / ₂ "W x 3 ³ / ₄ "H sign) and two Flat Side Panels ⑤ (Fits 18 ³ / ₈ "W x 3 ³ / ₄ "H sign) for FSD and FSDT models
FDWD-2CB	One Curved Front Panel ③ and one Curved Back Panel ④ (Fits 22 ¹ / ₄ "W x 3 ³ / ₄ "H sign) and two Flat Side Panels ⑤ (Fits 15 ¹ / ₂ "W x 3 ³ / ₄ "H sign) for FDWD models

F-LEGS-4	4" Adjustable Legs for FSD and FSDT models
FDWD-LEGS	4" Adjustable Legs for FDWD models

COLORS AND FINISHES – INSIDE BACK COVER



FSDT-1 with 4-tier circle rack and full Decorative Kit (signs not included)

Display Rack Selections

Racks For FDWD Models (Page 184)

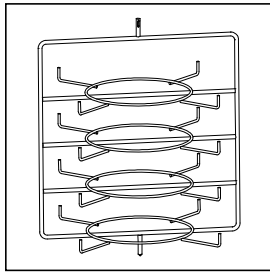

4-Tier Circle Rack
FDWD4TCRR
 (Max. 15" dia. pans)
 (3¼" between tiers)

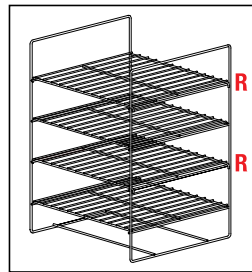

4-Shelf Multi-Purpose Rack
FDW4SMP (Max. 18" x 13")
 (Half-Size Sheet Pans fit
 FDWD-2 and -2X models only)
 (3¾" between shelves)

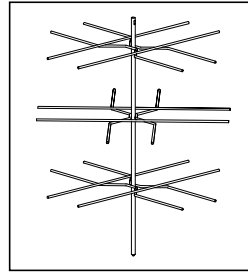

3-Tier Pretzel Tree
FDW3TPT
 (5⅞" between tiers)

Racks For FSD Models (Page 185)

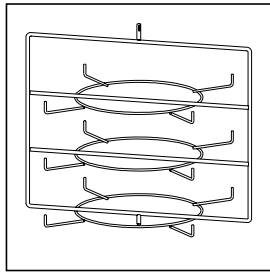

3-Tier Circle Rack
FSD3TCR
 (4⅝" between tiers)

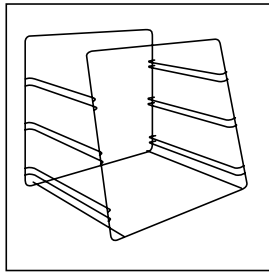

3-Tier Pan Rack
FSD3TPR
 (3½" between shelves)

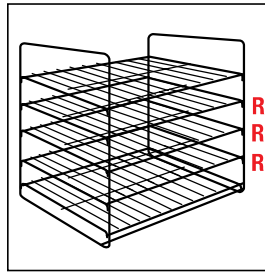

5-Shelf Multi-Purpose Rack
FSD5SMP
 (2½" between shelves)

Holding & Display Cabinets

Racks For FSDT Models (Page 185)

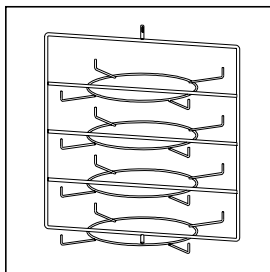

4-Tier Circle Rack
FSDT4TCR
 (Max. 19" dia. pans)
 (4⅝" between tiers)

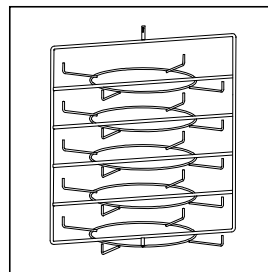

5-Tier Circle Rack
FSDT5TCR
 (Max. 19" dia. pans)
 (3⅞" between tiers)

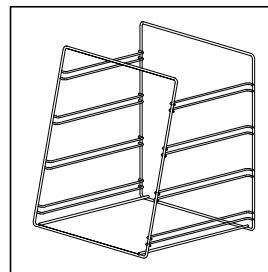

4-Tier Pan Rack
FSDT4TPR
 (Max. 18" x 13" Half-Size Sheet
 Pans) (3½" between tiers)

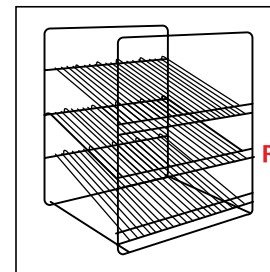

3-Shelf Angle Rack
FSDT3SAR
 (3½" between shelves)

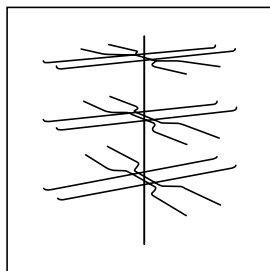

3-Tier Pretzel Tree
FSDT3TPT
 (5⅞" between tiers)

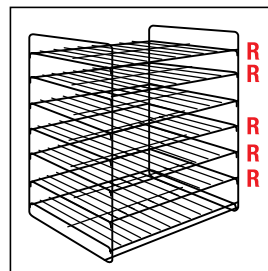

7-Shelf Multi-Purpose Rack
FSDT7SMP
 (Max. 18" x 13" Half-Size Sheet
 Pans) (2½" between shelves)

R Removable Shelves

Intelligent Heated Display Cabinet, Humidified

Hatco's Intelligent Heated Display Cabinet Humidified is the perfect way to showcase your pizzas and more. Regulating air temperature while at the same time balancing the humidity levels provides the best environment for food products. With 360° viewing, your food is guaranteed to get all the attention.

- Air flow pattern is designed to maintain consistent cabinet temperature without drying out food
- Air flow system enables the cabinet to recover temperature rapidly after opening and closing the door
- LCD touchscreen display on back of unit controls temperature, humidity and up to eight timers for each food location
- Energy efficient LED lighting to illuminate your food display
- USB port on back of unit makes it easy to update firmware
- Adjustable arms can move up and down the back supports
 - IHDC-45 can hold up to six pizza arms, can be adjusted up to 19.5" and can hold up to 8.5 lbs.
 - IHDC-28 arms will hold up to a 22" pizza pan



IHDC-45
shown with three optional shelves and French Front Doors



IHDC-45
shown with accessory arms and risers



IHDC-28
shown with accessory two arms and one shelf

Holding & Display Cabinets

NOTE: Water filter, water strainer and plastic tubing are included with each cabinet to be installed on water supply connection.

INTELLIGENT HEATED DISPLAY CABINETS – HUMIDIFIED

Model	Dimensions W x D x H	Cabinet Opening Dimensions (W x H)	Voltage	Watts	Amps	Plugs	Approx. Ship Weight
IHDC-28	28 1/4" x 28 3/4" x 30 1/4"	22" x 20 5/8"	208 240	3090	14.9 or 12.9	NEMA 6-20P	220 lbs.
IHDC-45	45" x 28 3/4" x 30 1/4"	18" x 20 7/8"	208 240	3090	14.9 or 12.9	NEMA 6-20P	270 lbs.

All Intelligent Heated Display Cabinet Models Feature:

Models Shipped With: IHDC-28: Stainless Steel unit with single french door, touchscreen controller, a lighted Power On/Off (I/O) switch, an air heating/circulation system, a humidity system, a USB port and LED display lights.

IHDC-45: Stainless Steel unit with sliding glass doors, touchscreen controller, a lighted Power On/Off (I/O) switch, an air heating/circulation system, a humidity system, a USB port and LED display lights.

Cord Location: Server side, lower left corner.

OPTIONS AND ACCESSORIES – PAGE 190
WATER QUALITY REQUIREMENTS – PAGE 247

On all Intelligent Heated Display Cabinet Models customers must purchase arms and shelves separately to their own specifications.

Below are the options available to combine the shelves and arms

IHDC-28

- 4 Arms
- 3 Shelves
- 1 Shelf with 1 Pizza Arm
- 1 Shelf with 2 Pizza Arms
- 2 Shelves with 1 Pizza Arm

IHDC-45

- 6 Arms
- 3 Slanted Shelves
- 1 Shelf with 2 Pizza Arms
- 1 Shelf with 4 Pizza Arms
- 2 Shelves with 2 Pizza Arms





IHDC-45 shown with accessory arms, accessory risers and sign holders

OPTIONS (available at time of purchase only)

Designer Colors – Non-standard colors are non-returnable – Stainless Steel Standard –

IHDCH-BK	Unit in <i>Designer Black</i> in lieu of Stainless Steel unit
IHDCBASE-BK-28	Inside base in <i>Designer Black</i> in lieu of Stainless Steel base for IHDC-28
FRTDOOR-28	Front, swing out door for IHDC-28, left-hand hinge standard, matches unit color (adds 2" to depth)
IHDCBASE-BK-45	Inside base in <i>Designer Black</i> in lieu of Stainless Steel base for IHDC-45
FRFRTDOOR-45	Front, self-closing French doors for IHDC-45, matches unit color (adds 2" to depth)

ACCESSORIES (available for purchase at any time)

ADJARM-SS	Pizza Arm in Stainless Steel
ADJARM-BK	Pizza Arm in <i>Designer Black</i>
SHELF-SS-28	Shelf in Stainless Steel for IHDC-28
SHELF-BK-28	Shelf in <i>Designer Black</i> for IHDC-28
SHELF-SS-45	Shelf in Stainless Steel for IHDC-45
SHELF-BK-45	Shelf in <i>Designer Black</i> for IHDC-45
RISER12-SS	12" diameter x 1½" H Riser in Stainless Steel
RISER12-BK	12" diameter x 1½" H Riser in <i>Designer Black</i>
DOORLOCKIHDC	Front Door lock for IHDC-28 only
RO KIT	Reverse Osmosis System with storage tank
REGKIT	Water Pressure Regulator Kit (regulator, gauge and shut-off valve)

SIGN HOLDERS (signs not included) – recommended sign size: 2" x 3.5" –

SGNHOLD-BASE-SS	Sits on base of unit in Stainless Steel
SGNHOLD-BASE-BK	Sits on base of unit in <i>Designer Black</i>
SGNHOLD-LARM-SS	Customer left-hand side in Stainless Steel (clips onto Arm)
SGNHOLD-LARM-BK	Customer left-hand side in <i>Designer Black</i> (clips onto Arm)
SGNHOLD-RARM-SS	Customer right-hand side in Stainless Steel (clips onto Arm)
SGNHOLD-RARM-BK	Customer right-hand side in <i>Designer Black</i> (clips onto Arm)

FOOD PANS AND TRIVETS – PAGE 245
COLORS AND FINISHES – INSIDE BACK COVER

Flav-R-Savor® Humidified Large Capacity Display Cabinets

Hatco Large Capacity Holding Cabinets hold more product at proper serving temperatures than standard size models. This allows for food to be prepared in advance of peak serving periods, while placing product in full-view cabinets to increase impulse sales.

- Full-view display with tempered glass sides and LED lighting to illuminate holding area
- Optional self-closing sliding doors for self-serve applications
- Optional self-closing French doors,
- Optional cool LED lighting and 4" adjustable legs available
- Multi-purpose display racks included



WFST-2X with 4-shelf multi-purpose rack, optional Designer Warm Red, self-closing sliding doors and accessory food pans, and 4" legs



WFST-1X with 4-shelf multi-purpose rack. Decals and pans not included

HUMIDIFIED LARGE CAPACITY CABINETS

Model	Description	Dimensions W x D x H	Voltage	Watts	Amps	Plugs*	Approx. Ship Weight
WFST-1X	2 Doors w/4-Shelf Rack	32 $\frac{1}{8}$ " x 25 $\frac{1}{4}$ " x 32 $\frac{3}{4}$ "	120 or 120/208-240	1715 or 2315	14.3	NEMA 5-15P	182 lbs.
WFST-2X	4 Doors w/4-Shelf Rack	32 $\frac{1}{8}$ " x 27 $\frac{3}{8}$ " x 32 $\frac{3}{4}$ "	120 or 120/208-240	1715 or 2315	14.3	NEMA 5-15P	188 lbs.

* Canadian models use NEMA 5-20P.

All Humidified Capacity Cabinet Models Feature:

Cabinet Opening Dimensions: 28"W x 21 $\frac{1}{8}$ "H.

Available Shelf Space: 26 $\frac{1}{4}$ "W x 19 $\frac{3}{4}$ "D. Holds one full-size sheet pan per shelf.

Water Tank Capacity for Humidity System: $\frac{3}{4}$ gallon.

Cord Location: Server side, left-hand side panel, lower right corner.

WATER QUALITY REQUIREMENTS – PAGE 247

Holding &
Display Cabinets

OPTIONS (available at time of purchase only)

Designer Colors – Non-standard colors are non-returnable –

– Clear Anodized Aluminum Standard –

RED	Warm Red
BLACK	Black
GRAY	Gray Granite
WHITE	White Granite
NAVY	Navy Blue
GREEN	Hunter Green
COPPER	Antique Copper
1SLIDE-DR	Self-closing Sliding Doors in lieu of standard Hinged Doors (WFST-2X only)
FRSELFLOSE	Self-Closing French Doors
WFST-TTC	Temperature Control Timer - 6 channel control touchscreen display
LED-NW18	Neutral White (cool) LED lighting (in lieu of standard Warm White)

ACCESSORIES (available for purchase at any time)

FSTCR-LEG	4" Adjustable Legs
------------------	--------------------

FOOD PANS AND TRIVETS – PAGE 245

COLORS AND FINISHES – INSIDE BACK COVER

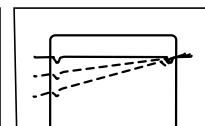
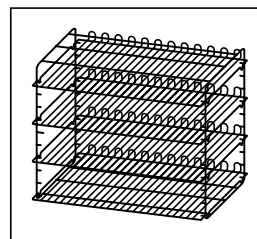

**WFST 4-Shelf
Multi-Purpose Rack**
Adjustable Shelves
in 2" increments

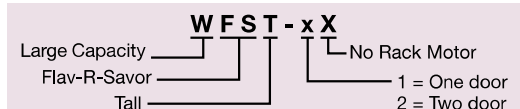

Flav-R-Savor® Non-Humidified Large Capacity Display Cabinets

When capacity is an issue, Hatco's Large Capacity Holding Cabinet is perfect for wrapped or bagged product. Designed to hold prepared foods for prolonged periods of time, while maintaining that "just-made" quality, allows for advanced preparation of peak serving periods.

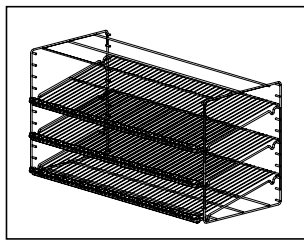

LFST 3-Shelf Multi-Purpose Rack with adjustable shelves in 2" increments

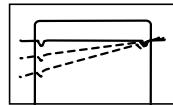

- Countertop cabinets with self-closing French-style glass doors
- Standard sign holders on all four sides of the cabinet (signs not included)
- Full-view display with tempered glass sides and incandescent lights to illuminate holding area
- Multi-purpose display rack included
- Perfect for large quantities of wrapped or boxed food
- Holds two standard sheet pans side-by-side on three shelves for increased product visibility and easy accessibility



LFST-48-2X with 3-shelf multi-purpose rack, sign holders (signs not included) and optional *Designer Warm Red*

Holding & Display Cabinets

NON-HUMIDIFIED LARGE CAPACITY CABINETS

Model®	Bulbs	Description	Dimensions W x D x H	Plug	Approx. Ship Weight
LFST-48-1X	6	Front Glass, Back French Doors	48 ⁷ / ₈ " x 25 ⁵ / ₈ " x 30"	NEMA L14-20P	222 lbs.
LFST-48-2X	6	Front and Back French Doors	48 ⁷ / ₈ " x 27 ¹ / ₈ " x 30"	NEMA L14-20P	230 lbs.

Ⓜ When no color is specified, unit will be Black.

All Non-Humidified Large Capacity Cabinet Models Feature:

Voltage: 120/208-240, 2150 watts, 14.6 amps.

Cabinet Opening Dimensions: 44"W x 22"H.

Available Shelf Space: 41³/₄"W x 17"D. Holds three, half-size sheet pans per shelf.

Cord Location: Server side, left-hand side panel, lower right corner.

OPTIONS (available at time of purchase only)

Designer Colors – Non-standard colors are non-returnable – Black Standard –

CLEAR	Clear Anodized Aluminum
RED	Warm Red
GRAY	Gray Granite
WHITE	White Granite
NAVY	Navy Blue
GREEN	Hunter Green
COPPER	Antique Copper
HAL	60 Watt Halogen Bulb in lieu of Standard Display Light

FOOD PANS AND TRIVETS – PAGE 245

COLORS AND FINISHES – INSIDE BACK COVER

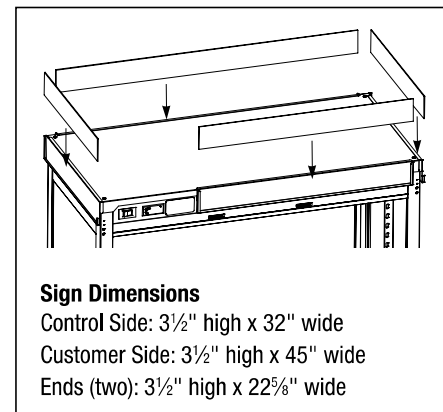

Sign Dimensions

Control Side: 3¹/₂" high x 32" wide
Customer Side: 3¹/₂" high x 45" wide
Ends (two): 3¹/₂" high x 22⁵/₈" wide

LFST Cabinet comes with sign holders attached on all four sides, with clear plastic inserts (signs not included)

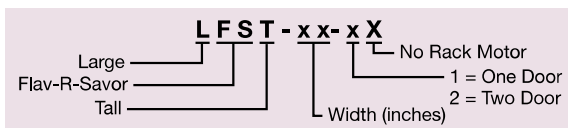

Non-Humidified Mini Display Warmers

The Hatco Mini Display Warmer is perfect for cookies, pastries, wrapped or boxed sandwiches or any other product that does not require humidity. Hot air circulates throughout the entire cabinet, keeping food at safe serving temperatures. The small footprint takes up little of your valuable counterspace while merchandising your breakfast, lunch or dinner offerings.

MDW-1X with standard *Designer Black* and optional Hood with backlit sign cutout on one side (sign included)

- Magnetically adjustable shelves allow horizontal or slanted displays
- Tempered glass sides and incandescent light
- Available as a 1- or 2-door pass-through model
- Doors may be field converted to any side
- Optional black hood with backlit graphic sign cutout that can be rotated in field to face any side (sign included)



Magnetically adjustable shelves are easy and offer quick adjustability for different food products

MINI DISPLAY WARMERS – NON-HUMIDIFIED

Model	Description	Dimensions	Voltage	Watts	Amps	Plug	Approx. Ship Weight
		W x D x H					
MDW-1X	1 Door w/3 Shelves	15¾" x 17" x 25½"	120	470	3,9	NEMA 5-15	46 lbs.
MDW-2X	2 Doors w/3 Shelves	15¾" x 18¾" x 25½"	120	470	3,9	NEMA 5-15	53 lbs.

All Mini Display Warmer Models Feature:

Cabinet Opening Dimensions: 12½"W x 15¾"H.

Door Hinges: **Control Side:** Left-hand side.

Customer Side (two-door models only): Right-hand side.

Cord Location: Server side, lower right corner.

Holding & Display Cabinets

OPTIONS (available at time of purchase only)

Designer Color for Posts, Base, and Top Trim – Non-standard colors are non-returnable

– **Black Standard** –

RED	Warm Red
GRAY	Gray Granite
WHITE	White Granite
NAVY	Navy Blue
GREEN	Hunter Green
COPPER	Antique Copper
BCKLIT-MDW	Hood with Backlit Sign cut out on one side - Black only (sign included)

COLORS AND FINISHES – INSIDE BACK COVER

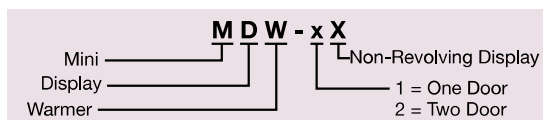

Non-Humidified Macho Nacho® Chip Warmers

Keep your nacho chips hot, fresh and crisp with Hatco's Macho Nacho® Chip Warmer. This highly-visible heated merchandiser circulates air to prevent the loss of natural oils, eliminating the need to frequently replace stale chips.

- Keeps chips hot, fresh and crisp longer, reducing refill time and minimizing waste
- Specialty cabinets to hold and/or merchandise bulk nacho chips
- Special ductwork forces dry heat through chips from the bottom up
- Special two-door access for easy loading and serving
- 25 lb. or 40 lb. capacity
- Shatter-resistant incandescent lights illuminate the holding areas and emphasize the product



FDWD-1-MN



FST-1-MN shown in standard Bronze

Holding & Display Cabinets

CHIP WARMERS – NON-HUMIDIFIED

Model	Dimensions W x D x H	Product Capacity	Voltage	Watts	Plug	Approx. Ship Weight
FDWD-1-MN	19 ³ / ₈ " x 24" x 28 ⁷ / ₈ "	25 lbs.	120	1080	NEMA 5-15P	101 lbs.
FST-1-MN	22 ⁷ / ₈ " x 27" x 32 ¹ / ₈ "	40 lbs.	120	1245	NEMA 5-15P	132 lbs.

All Chip Warmer Models Feature:

Cabinet Opening: FDWD-1-MN: Upper Door: 16³/₈"W x 9¹/₂"H.
Lower Door: 16³/₈"W x 9¹/₂"H.

FST-1-MN: Upper Door: 18³/₈"W x 11¹/₄"H.
Lower Door: 18³/₈"W x 9¹/₂"H.

Decal Size: FDWD-1-MN: 16³/₈"W x 5¹/₂"H.
FST-1-MN: 18³/₈"W x 6"H.

Cord Location: Facing controls, left-hand side panel, lower right corner.

x x x x - 1 - M N

FDWD = 25 lbs. chip capacity
FST = 40 lbs. chip capacity

Macho Nacho Unit
Single Side Opening

Flav-R-Savor® Tall Non-Humidified Holding Cabinets

Be prepared to serve ready-to-go pizzas with Hatco's Flav-R-Savor® Tall Dry Holding Cabinets. An eight-shelf rack with 5" centers will hold a maximum of 16 boxed (18" Sq x 2⁵/₁₆" H maximum) or 8 bagged pizzas.

- Great for boxed or bagged carryout pizzas
- Tempered glass throughout for excellent visibility, improving product rotation
- Even, constant cabinet temperatures with no humidity
- Two, shatter-resistant, incandescent lights at the back top of the unit to illuminate product
- Units come with an eight-shelf rack, six of which are removable



PFST-2X with standard stainless steel 8-shelf rack



PFST-1XB with standard Glossy White 8-shelf rack

Holding & Display Cabinets

TALL HOLDING CABINETS – NON-HUMIDIFIED

Model	Description	Dimensions W x D x H	Opening Dimensions W x H	Voltage	Watts	Plug*	Approx. Ship Weight
Standard							
PFST-1X	1 Door	22 ⁷ / ₈ " x 25" x 57"	18 ³ / ₄ " x 40 ³ / ₈ "	120	1767	NEMA 5-15P	200 lbs.
PFST-2X	2 Doors	22 ⁷ / ₈ " x 27 ¹ / ₄ " x 57"	18 ³ / ₄ " x 40 ³ / ₈ "	120	1767	NEMA 5-15P	207 lbs.
With Base							
PFST-1XB	1 Door	24 ³ / ₄ " x 25 ¹ / ₂ " x 70"	18 ³ / ₄ " x 40 ³ / ₈ "	120	1767	NEMA 5-15P	258 lbs.

* Canadian models use NEMA 5-20P.

All Tall Dry Holding Cabinet Models Feature:

Models Shipped with: PFST-1X, -2X: Stainless Steel body, an eight-shelf rack with 6 removable shelves in standard stainless steel, new latching handle, 5" locking casters, cord and plug.

PFST-1XB: Solid back panel, stainless steel inside, (with painted Glossy Gray on the outside), an eight-shelf rack with 6 removable shelves in standard Smooth White, front and side sign holders painted Glossy Gray with flip-up side for access to controls (signs not included), 11" high Designer Black base, latching handle, 4" locking casters, cord and plug.

Available Shelf Space: 18" square x 4⁵/₈" height.

Cord Location: Facing controls, left-hand side panel, bottom right corner.

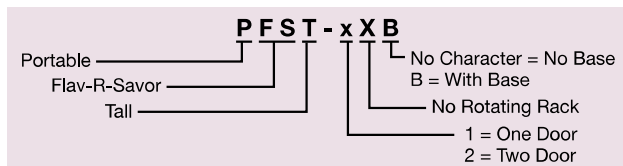

OPTIONS (available at time of purchase only)

Designer Color – Non-standard colors are non-returnable –
– Clear Anodized Aluminum Standard –
BLACK Black

COLORS AND FINISHES – INSIDE BACK COVER



Flav-R-Savor® Portable Holding Cabinets

Hatco's energy efficient Flav-R-Savor® Portable Holding Cabinets will keep prepared foods at optimum serving temperatures for hours. The thermostatically-controlled heat and humidity allows food to be prepared in advance of peak serving periods.

- Allows you to hold product longer while saving you money through increased energy efficiencies
- Electronic control with digital read out, temperature range of 80°- 200°F and humidity controller
- The lower temperature range of 80°-100°F can be used for proofing all types of breads
- All stainless steel interior
- No heating element in direct contact with water makes the unit easier to clean
- Accommodates Gastronorm pans
- Electrical components, controls and digital temperature readout are located at the top for easy access
- Stacking kit available
- Doors are field convertible from left to right



FSHC-7W1-EE shown in Designer Black, with optional bumper kit, and right-hand hinged door



PORTABLE HOLDING CABINETS

Model	Description	Dimensions				Voltage	Hz	Watts	Amps	Plug	Approx. Ship Weight
		W x D x H <i>Height includes standard casters</i>									
FSHC-5W1-EE	Single Door	26 1/8"	x 31 1/4"	x 36"	120	60	1118	9.3	NEMA 5-15P	250 lbs.	
FSHC-7W1-EE	Single Door	26 1/8"	x 31 1/4"	x 39"	120	60	1118	9.3	NEMA 5-15P	222 lbs.	
FSHC-7W2-EE	2-Door Pass-Through	26 1/8"	x 34 3/8"	x 39"	120	60	1118	9.3	NEMA 5-15P	232 lbs.	

All Portable Holding Cabinet Models Feature:

Interior Cabinet Capacity: 20 7/8"W x 26 7/8"D.

Top Surface Dimensions: 25 3/4"W x 28 1/2"D.

Models Shipped with: 6' cord and plug, 4" diameter casters (with 5 1/8" clearance), stainless steel heavy-duty door with left-hand door hinge, and adjustable rack slides (seven for the -7WX-EE units, and five for the -5W1-EE unit).

Pan Capacity: -5W1-EE: 10 full sized sheet pans or 2/1 Gastronorm pans on 1 3/8" spacing, 5 full sized sheet pans or 2/1 Gastronorm pans on 3 1/4" spacing, 10 full sized hotel pans or 1/1 Gastronorm pans on 1 3/8" spacing.
-7Wx-EE: 14 full sized sheet pans[□] or 2/1 Gastronorm pans on 1 3/8" spacing, 7 full sized sheet pans or 2/1 Gastronorm pans on 2 3/4" spacing, 14 hotel sized pans or 1/1 Gastronorm pans on 1 3/8" spacing.

Water Tank Capacity for Humidity System: 1 gallon.

Cord Location: Recessed, back of unit, upper right side.

[□] With purchase of extra pan slides.



FSHC-7W1-EE & FSHC-7W2-EE (120V models only) NOTE: Units equipped with a heavy-duty glass door(s) are not ENERGY STAR qualified

WATER QUALITY REQUIREMENTS – PAGE 247

OPTIONS (available at time of purchase only)

Colors (Side Panels) – Non-standard colors are non-returnable – Black standard –

SS Stainless Steel

Colors (Top) – Non-standard colors are non-returnable – Black standard –

SS Stainless Steel

EE-GLASS Glass Door (in lieu of stainless steel door) (is not Energy Star qualified)

EE-LPCAST Low profile casters (FSHC-5W1-EE model only) (deduct 2 1/4" from height)

EE-PLATFORM Platform for mounting directly on a counter (deduct 4 1/8" from height) (in lieu of casters)

EE-STACK-BLK Designer Black powdercoated stacking hardware mounted to bottom of cabinet for two FSHC-7W1 or two FSHC-5W1 units in lieu of casters (cannot have legs on lower unit)

EE-STACK-SS Stainless steel stacking hardware mounted to bottom of cabinet for two FSHC-7W1 or two FSHC-5W1 units in lieu of casters (cannot have legs on lower unit)

EE-BUMPER Bumper Hardware (only for use with standard casters) (add 1/8" to height)

EE-4LEGS 4" legs (in lieu of casters, deduct 1/2" from height)

EE-6LEGS 6" legs (in lieu of casters, add 1 1/4" to height)

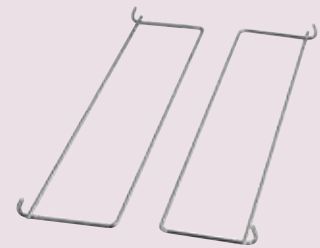

EE-1-SLIDE Accessory

ACCESSORIES (available for purchase at any time)

EE-1-SLIDE Extra Pan Slides

FOOD PANS AND TRIVETS – PAGE 245

COLORS AND FINISHES – INSIDE BACK COVER



Flav-R-Savor® Low Profile, Humidified, Portable Holding Cabinets

Prepare food in advance of peak serving periods and safely hold it at optimum serving temperatures with the Flav-R-Savor® Portable Holding Cabinet. Thermostatically-controlled heat and humidity allows you to hold product for hours.

- Thermostatically-controlled heat and humidity holds hot food at optimum serving temperatures longer
- Allows preparation of food in advance of peak serving periods
- Accommodates Gastronorm pans
- Electrical components, controls, water reservoir and digital temperature readout are located at the top for easy access
- Reduced height – less than 30" high, and wider footprint for increased capacity
- Insulated side walls, field reversible glass doors, large swivel casters with wheel locks and 6" recessed cord and plug are standard
- Stacking kit available



FSHC-6W1 with accessory food pans

LOW PROFILE HOLDING CABINETS – HUMIDIFIED

Model	Description	Dimensions (W x D x H) <i>Height includes standard casters</i>	Cabinet Opening (W x H)	Top Surface Dimensions (W x D)	Plug	Approx. Ship Weight
FSHC-6W1	1 Door	25½" x 29⅝" x 32⅞"	21½" x 19"	25⅝" x 25⅝"	NEMA 5-15P	167 lbs.
FSHC-6W2	2 Doors	25½" x 32" x 32⅞"	21½" x 19"	25⅝" x 25⅝"	NEMA 5-15P	180 lbs.

† FSHC-6W2 is a two-door pass-through single cabinet, not two units stacked.

All Low Profile Holding Cabinet Models Feature:

Voltage: 120, 60 Hz, 1697 watts, 14.1 amps, NEMA 5-15P (NEMA 5-20P Canada).

Models Shipped with: 6' cord and plug, 4" diameter casters (with 5/8" clearance), six sets of adjustable angle slides.

Pan Capacity: Six 18"W x 26"D sheet pans or six 2/1 Gastronorm pans on 3" centers, eleven 18"W x 26"D sheet pans[‡], eleven 2/1 Gastronorm pans on 1½" centers[‡], or twelve 20"W x 12"D x 2½"H hotel pans[‡].

Water Tank Capacity for Humidity System: ¾ gallon.

Cord Location: Recessed, back of unit, upper right side.

[‡]With purchase of extra pan slides.

WATER QUALITY REQUIREMENTS – PAGE 247

Holding & Display Cabinets

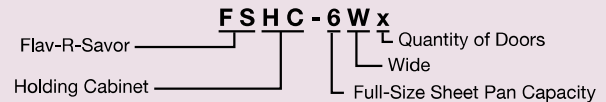

OPTIONS (available at time of purchase only)

Colors (Side Panels) – Non-standard colors are non-returnable – Silver Gray Standard –

BLACK Designer Black

SS Stainless Steel

Colors (Top) – Non-standard colors are non-returnable – Silver Gray Standard –

BLACK Designer Black

SS Stainless Steel

6W-SS-DR Stainless Steel Door in lieu of Glass Door

HD-SS-DR Heavy-Duty Stainless Steel Door with Positive Latch Handle

6W1-LPCAST 2" Low Profile Locking Casters in lieu of standard Casters (2" diameter with 3" clearance - Overall height is 29¾")

6W1-STACK Stacking Hardware mounted to top of Cabinet for two FSHC-6W1 Units in lieu of Casters (Silver Gray)

CORDWIND Bracket for holding Cord during transport

ACCESSORIES (available for purchase at any time)

6W1-SLIDE Extra Pan Slides

FOOD PANS AND TRIVETS – PAGE 245 COLORS AND FINISHES – INSIDE BACK COVER

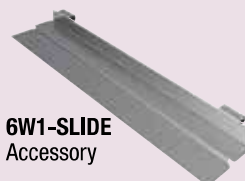

6W1-SLIDE
Accessory

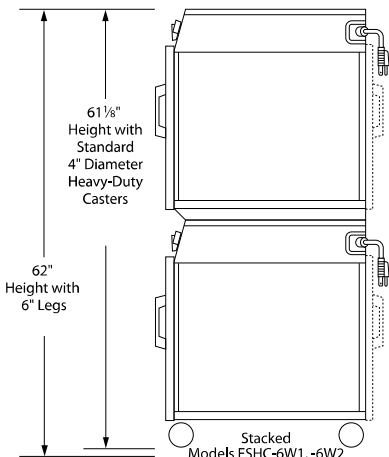
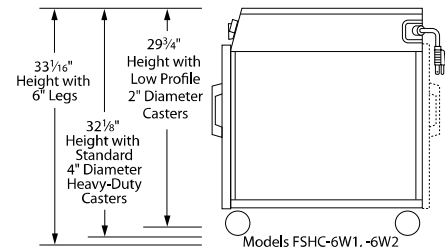

Flav-R-Savor® Humidified Portable Holding Cabinets

Prepare food in advance of peak serving periods and safely hold it at optimum serving temperatures with the Flav-R-Savor® Portable Holding Cabinet. Thermostatically-controlled heat and humidity allows you to hold product for hours.

- Thermostatically-controlled heat and humidity holds hot food at optimum serving temperatures longer
- Allows preparation of food in advance of peak serving periods
- Accommodates Gastronorm pans
- Electrical components, controls, water reservoir and digital temperature readout are located at the top for easy access
- Insulated side walls, field reversible glass doors, large swivel casters with wheel locks and 6" recessed cord and plug are standard
- Stacking kit available



FSHC-7-1 with standard 4" casters and accessory food pans

PORTABLE HOLDING CABINETS – HUMIDIFIED

Model	Description	Dimensions (W x D x H) <i>Height includes standard casters</i>	Cabinet Opening (W x H)	Top Surface Dimensions (W x D)	Plug	Approx. Ship Weight
FSHC-7-1	1 Door	22 ³ / ₄ " x 29 ⁵ / ₈ " x 35 ¹ / ₈ "	18 ¹ / ₂ " x 22"	22 ⁵ / ₈ "W x 25 ⁷ / ₈ "	NEMA 5-15P	175 lbs.
FSHC-7-2	2 Doors	22 ³ / ₄ " x 32" x 35 ¹ / ₈ "	18 ¹ / ₂ " x 22"	22 ⁵ / ₈ "W x 25 ⁷ / ₈ "	NEMA 5-15P	180 lbs.

⚠ FSHC-7-2 is a two-door pass-through single cabinet, not two units stacked.

All Portable Holding Cabinet Models Feature:

Voltage: 120, 60 Hz, 1697 watts, 14.1 amps, NEMA 5-15P Canada (NEMA 5-20P Canada).

Models Shipped with: 6' cord and plug, 4" diameter casters (with 5¹/₈" clearance), seven sets of adjustable angle slides for 18" x 26" pans or 12" x 20" pans.

Pan Capacity: Seven 18" x 26" sheet pans on 3" centers, seven 20" x 12" x 2¹/₂" hotel pans or seven 1/1 Gastronorm pans.

Water Tank Capacity for Humidity System: 3/4 gallon.

Cord Location: Recessed, back of unit, upper right side.

WATER QUALITY REQUIREMENTS – PAGE 247

OPTIONS (available at time of purchase only)

Colors (Side Panels) – Non-standard colors are non-returnable – Silver Gray Standard –

BLACK Designer Black

SS Stainless Steel

Colors (Top) – Non-standard colors are non-returnable – Silver Gray Standard –

BLACK Designer Black

SS Stainless Steel

SS-DR Stainless Steel Door in lieu of Glass Door

HD-SS-DR Heavy-Duty Stainless Steel Door with Positive Latch Handle

LWALARM Audible Low-Water Alarm

LPCAST 2" Low Profile Casters in lieu of Standard Casters (2" diameter with 3" clearance - Overall Height 32³/₄")

4LEGS 4" Adjustable Legs in lieu of standard Casters

6SS 6" Stainless Steel Legs in lieu of standard Casters

7-1-STACK Stacking Hardware mounted to top of cabinet for two FSHC-7-1 units in lieu of Casters (Silver Gray)

CORDWIND Bracket for holding cord during transport

ACCESSORIES (available for purchase at any time)

SLIDEWIRE Wire Shelf

FOOD PANS AND TRIVETS – PAGE 245

COLORS AND FINISHES – INSIDE BACK COVER

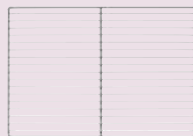

SLIDEWIRE
Accessory

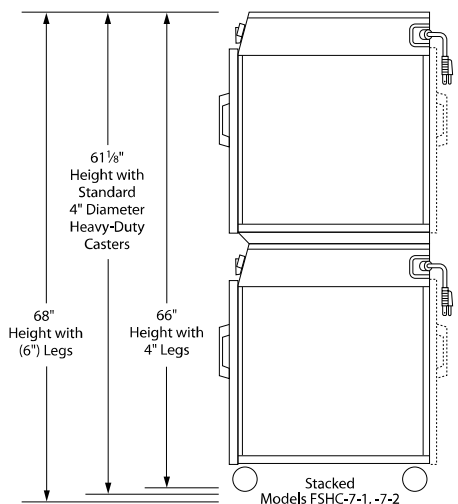
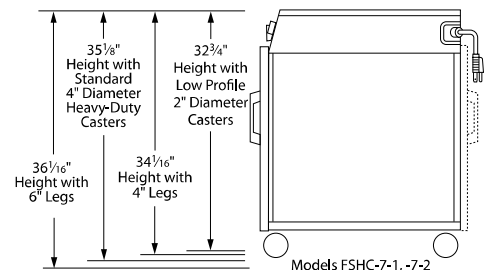
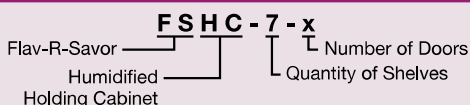

Flav-R-Savor® Tall Humidified Holding Cabinets

The expanded capacity of Hatco's Tall Humidified Cabinets offers flexibility – giving customers more variety of menu items, and holding larger quantities of proven favorites ahead of peak serving periods. The universal slides of the FSHC-17W models will hold 17 sheet pans or 34 steam table pans. FSHC-12W models will hold 12 sheet pans and 24 steam table pans.

- Electronic controls with digital readout temperature range of 80°-200°F with precise heat and humidity settings assure uniform heating throughout the cabinet
- Using the lower temperature range of 80°-100°F allows perfect temperature for proofing all types of bread
- Lexan or stainless steel doors, full height, half height and pass-through available
- All Stainless Steel interior and exterior
- Fully insulated doors, sidewalls, base and top assist in heat retention and quick recovery
- Field reversible, right- or left-hand hinged doors with magnetic latch and heavy-duty plated hinges
- Fully welded tubular frame assures integrity of unit in any working environment



FSHC-12W1
with optional
Stainless Steel door



FSHC-17W1

Holding & Display Cabinets

TALL HUMIDIFIED HOLDING CABINETS

Model*	Description	Dimensions W x D x H †	Voltage Single Phase	Watts	Amps	Plugs	Approx. Ship Weight
FSHC-12W1	Single Lexan® Door	26" x 34¾" x 57¾"	120 208-240	1650 1608-2133	13.8 7.7-8.9	NEMA 5-15P NEMA 6-15P	303 lbs.
FSHC-12W2	2 Lexan® Doors – Pass-Through	26" x 35¾" x 57¾"	120 208-240	1650 1608-2133	13.8 7.7-8.9	NEMA 5-15P NEMA 6-15P	316 lbs.
FSHC-17W1	Single Lexan® Door	26" x 34¾" x 73¾"	120 208-240	1650 1608-2133	13.8 7.7-8.9	NEMA 5-15P NEMA 6-15P	352 lbs.
FSHC-17W1D	Single Opening w/ 2 Dutch Doors	26" x 34¾" x 73¾"	120 208-240	1650 1608-2133	13.8 7.7-8.9	NEMA 5-15P NEMA 6-15P	360 lbs.
FSHC-17W2	2 Lexan® Doors – Pass-Through	26" x 35¾" x 73¾"	120 208-240	1650 1608-2133	13.8 7.7-8.9	NEMA 5-15P NEMA 6-15P	365 lbs.
FSHC-17W2D	4 Dutch Doors – Pass-Through	26" x 35¾" x 73¾"	120 208-240	1650 1608-2133	13.8 7.7-8.9	NEMA 5-15P NEMA 6-15P	389 lbs.

† Height includes standard casters.

* 120V Canadian Models use NEMA 5-20P.

All Tall Humidified Holding Cabinet Models Feature:

Cabinet Opening Dimensions: **FSHC-12W:** 22"W x 43½"H.

FSHC-17W: 22"W x 59¼"H.

Models Shipped with: 10' cord and plug, 5" casters, universal slides for 18" x 26" pans or 12" x 20" pans.

Pan Capacity – FSHC-12W: 12-sheet pan capacity on 3" centers, adjustable on 1½" centers, with 12 universal pan slides designed to accommodate up to 12 sheet pans or up to 24 steam table pans.

Pan Capacity – FSHC-17W: 17-sheet pan capacity on 3" centers, adjustable on 1½" centers, with 17 universal pan slides designed to accommodate up to 17 sheet pans or up to 34 steam table pans.

Water Reservoir Capacity for Humidity System: 2 gallons.

Cord Location: Recessed, facing controls, right-hand side panel, lower right corner.

OPTIONS AND ACCESSORIES – PAGE 200
WATER QUALITY REQUIREMENTS – PAGE 247

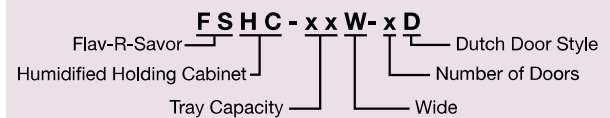



FSHC-17W1

OPTIONS (available at time of purchase only)

DELUXE	Deluxe Package (includes Flush Mount Handles and Full Perimeter Bumper)
TRANS	Transport Package (includes Stand-Off Handles, Full Perimeter Bumper, Heavy-duty 5" x 2" Casters (2 swivel with wheel locks and 2 rigid), and Flush Mount Transport Latch)
CORDWIND	Bracket for holding cord during transport (only available with Transport Package option for FSHC-12W and FSHC-17 models)
12W-SS-DOOR	Stainless Steel Door in lieu of Lexan® Door
17W-SS-DOOR	Stainless Steel Door in lieu of Lexan® Door
17WD-SS-DOOR	Stainless Steel Dutch Doors in lieu of Lexan® Dutch Doors (FSHC-17W models only)

ACCESSORIES (available for purchase at any time)

17W-SLIDE	Extra Pan Slides (FSHC-12W and FSHC-17W)
------------------	--



17W-SLIDE
Accessory

FOOD PANS AND TRIVETS – PAGE 245

Flav-R-Savor® Heated Air Curtain Cabinets

The patented Flav-R-Savor® Heated Air Curtain Cabinet effectively and safely holds hot food hot without the use of doors, allowing immediate access to product. Warm air at the front of the cabinet is forced downward, through the ducts above the opening, forming a “curtain” of heated air. A portion of the heated air is drawn toward the rear of the cabinet, warming each pan.



FS2HAC-15 with 1/3 size food pans (pans not included)

- Perfect for holding wrapped or sealed product like tortillas, burritos and ribs, as well as product on sheet pans like biscuits, hamburger patties and baked potatoes or fried foods in pans
- Available in 2-pan and 3-pan models, single opening or pass-through, with or without humidity
- The FS2HAC-15 holds 6, 1/3 size pans (pans not included)
- The 2-pan pass-through accommodates two full-size sheet pans or four half-size sheet pans, and the 4-pan unit accommodates four full-size sheet pans or eight half-size sheet pans
- FS2HAC-15 comes standard with a pan rack, removeable crumb tray, USB port and a touch screen control with temperature and timer display, and a 6' cord and plug



FSHACH-2 with accessory food pans



FS2HAC-2PT with accessory food pans

HEATED AIR CURTAIN CABINETS

Model	Description	Dimensions (W x D x H)	Cabinet Opening Dimensions (W x H)	Voltage	Watts	Amps	Plugs	Approx. Ship Weight
FSHAC-2 ‡	2-Tier Warmer	20 ⁷ / ₈ " x 22 ⁷ / ₈ " x 18 ¹ / ₈ "	18 ¹ / ₄ " x 9 ¹ / ₈ "	120	1850	15.4	NEMA 5-20P	102 lbs.
FSHAC-2 ‡	2-Tier Warmer	20 ⁷ / ₈ " x 22 ⁷ / ₈ " x 18 ¹ / ₈ "	18 ¹ / ₄ " x 9 ¹ / ₈ "	120/208	1877	9.0	NEMA L14-20P	102 lbs.
FSHAC-3 ‡	3-Tier Warmer	20 ⁷ / ₈ " x 22 ⁷ / ₈ " x 30 ¹ / ₂ "	18 ¹ / ₄ " x 18 ¹ / ₈ "	120/208	1877	9.0	NEMA L14-20P	105 lbs.
FS2HAC-15	Open Cavity Warmer	15 ¹ / ₂ " x 21 ¹ / ₄ " x 21 ³ / ₄ "	14 ³ / ₄ " x 13"	120	1105	9.2	NEMA 5-15P*	83 lbs.
FS2HAC-2PT ‡	2-Tier Pass-Through	24 ¹ / ₈ " x 39 ¹ / ₈ " x 18 ¹ / ₂ "	18 ¹ / ₁₆ " x 8 ¹ / ₈ "	120/208 or 120/240	2589	10.8	NEMA L14-20P	175 lbs.
FS2HAC-4PT ‡	4-Tier Pass-Through	24 ¹ / ₈ " x 39 ¹ / ₈ " x 26 ¹ / ₂ "	18 ¹ / ₄ " x 16 ¹ / ₈ "	120/208 or 120/240	3389	14.2	NEMA L14-20P	211 lbs.

‡ Height includes 4" legs.
* Canadian models use NEMA 6-15P.

All Heated Air Curtain Cabinet Models Feature:

Cord Location: FSHAC-2, -3: Top of unit towards the back, middle.
FS2HAC-15: Top of unit towards the back, right side.
FS2HAC-2PT, -4PT: Top of unit towards the back, left side.

HEATED AIR CURTAIN CABINETS – HUMIDIFIED

Model	Description	Dimensions (W x D x H)	Cabinet Opening Dimensions (W x H)	Voltage	Watts	Amps	Plugs	Approx. Ship Weight
FSHACH-2	2-Tier Warmer	20 ⁷ / ₈ " x 24 ³ / ₈ " x 18 ¹ / ₈ "	18 ¹ / ₄ " x 9 ¹ / ₈ "	120/208	2950	14.2	NEMA L14-20P	100 lbs.
FSHACH-3 ‡	3-Tier Warmer	20 ⁷ / ₈ " x 24 ³ / ₈ " x 30 ¹ / ₂ "	18 ¹ / ₄ " x 18 ¹ / ₈ "	120/208	2950	14.2	NEMA L14-20P	100 lbs.
FSHACH-2PT ‡	2-Tier Pass-Through	24 ¹ / ₈ " x 35 ⁵ / ₈ " x 22"	18 ¹ / ₄ " x 9 ¹ / ₄ "	120/208	4952	23.8	NEMA L14-30P	150 lbs.
FSHACH-2PT ‡	2-Tier Pass-Through	24 ¹ / ₈ " x 35 ⁵ / ₈ " x 22"	18 ¹ / ₄ " x 9 ¹ / ₄ "	208	4952	23.8	NEMA L6-30P	150 lbs.

‡ Height includes 4" legs.

All Humidified Heated Air Curtain Cabinet Models Feature:

Models Shipped with: Auto-fill water reservoir and water filter. 4" legs also come standard (excluding FSHACH-2).
Water Tank Capacity for Humidity System: FSHACH-2, -3: 2¹/₄ gallons.
FSHACH-2PT: 3 gallons.

Cord Location: FSHACH-2, -3: Top of unit towards the back, middle.
FSHACH-2PT: Top of unit towards the back, left side.

FOOD PANS AND TRIVETS – PAGE 245

