



GLO-RAY® MAX WATT DUAL INFRARED FOODWARMERS

Models GRAM-18D, -24D, -30D, -36D, -42D, -48D, -54D, -60D, -66D, -72D, -84D, -96D, -108D, -120D, -132D, -144D
GRAML-18D, -24D, -30D, -36D, -42D, -48D, -54D, -60D, -66D, -72D, -84D, -96D, -108D, -120D, -132D, -144D

Hatco Glo-Ray® Max Watt Dual Infrared Foodwarmers keep all hot foods at optimum serving temperatures longer. Foods do not dry out or become discolored; even the most delicate dishes hold that "just-prepared" look.

FLEXIBILITY

The Glo-Ray pre-focused heat pattern directs heat from a tubular element to bathe the entire holding surface. Units are available with shatter-resistant incandescent lights that illuminate the warming area.

Remote Control Enclosures are included. Built in accordance with UL Standards, it includes toggle switch, Electronic Infinite Control, relay, and indicator light

All models are shipped factory-assembled, with adjustable angle brackets (shipped loose), ready-to-install quickly and easily.

QUALITY

The following features assure the finest performance for years to come:

- Features 25% greater wattage output than Glo-Ray high watt by comparison, with dual units varying in wattage from 900 to 8300 watts; and units with lights varying from 1020 to 9020 watts
- Available in widths from 18" to 12' (457-3658 mm).
- Sturdy extruded aluminum housings eliminate sagging.
- Pre-focused heat maintains serving temperatures longer without continuing to cook the food.
- Shatter-resistant incandescent lights (standard) enhance product display while safeguarding food products from bulb breakage. An optional halogen bulb may be used in lieu of incandescents.
- Available in *Designer* colors: Warm Red, Black, Gray Granite, White Granite, Navy Blue, Hunter Green, and Antique Copper
- Available in Gloss finishes: Smooth White, Gleaming Gold, Glossy Gray, Bold Black, Radiant Red, Brilliant Blue



Model GRAML-96D
with optional non-adjustable
tubular stands

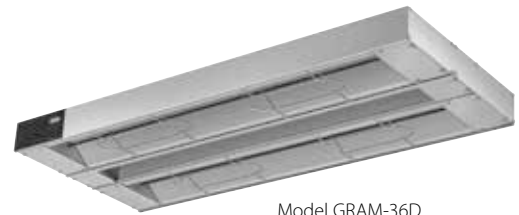

Model GRAM-36D
with 3" (76 mm) spacer

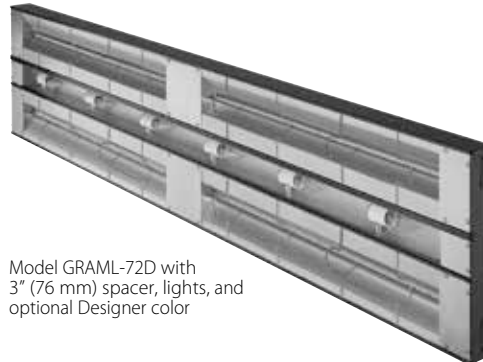

Model GRAML-72D with
3" (76 mm) spacer, lights, and
optional Designer color



ANSI/NSF 4

METAL SHEATHED ELEMENTS GUARANTEED AGAINST BURNOUT AND BREAKAGE FOR TWO YEARS.

HATCO CORPORATION P.O. Box 340500 Milwaukee, WI 53234-0500 U.S.A.
(800) 558-0607 • (414) 671-6350 • Fax (800) 543-7521 • Int'l. Fax (414) 671-3976
www.hatcocorp.com • E-mail: equipsales@hatcocorp.com

Form No. GRAM-D Spec Sheet

Printed in U.S.A.
July 2015



GLO-RAY® MAX WATT DUAL INFRARED FOODWARMERS

Models GRAM-18D, -24D, -30D, -36D, -42D, -48D, -54D, -60D, -66D, -72D, -84D, -96D, -108D, -120D, -132D, -144D
GRAML-18D, -24D, -30D, -36D, -42D, -48D, -54D, -60D, -66D, -72D, -84D, -96D, -108D, -120D, -132D, -144D

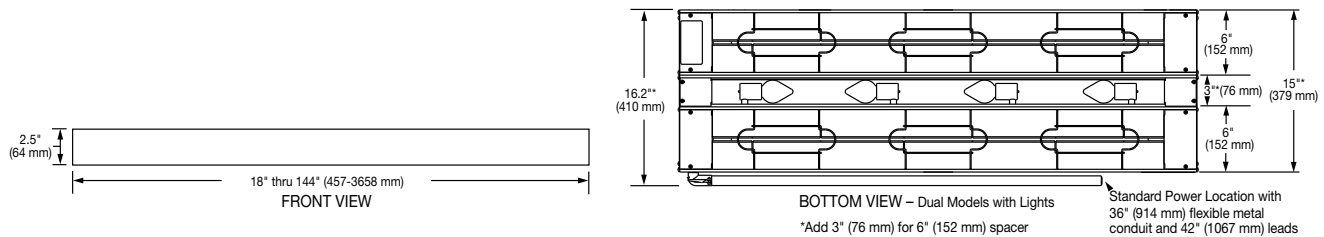

SPECIFICATION+

Glo-Ray® Max Watt Aluminum Dual Infrared Foodwarmer

Aluminum Max Watt		with Lights		Both Models	
Model	Watt	Model	Watt	Width	Shipping Weight [◇]
GRAM-18D	900	GRAML-18D	1020	18" (457 mm)	14 lbs (6 kg)/14lbs (6 kg)
GRAM-24D	1300	GRAML-24D	1420	24" (610 mm)	16 lbs (7 kg)/16lbs (7 kg)
GRAM-30D	1650	GRAML-30D	1770	30" (762 mm)	18 lbs (8 kg)/19lbs (9 kg)
GRAM-36D	2000	GRAML-36D*	2180	36" (914 mm)	21 lbs (10 kg)/22 lbs (10 kg)
GRAM-42D	2350	GRAML-42D*	2530	42" (1067 mm)	24 lbs (11 kg)/25 lbs (11 kg)
GRAM-48D	2600	GRAML-48D*	2840	48" (1219 mm)	27 lbs (12 kg)/29 lbs (13 kg)
GRAM-54D	3000	GRAML-54D*†	3240	54" (1372 mm)	30 lbs (14 kg)/34 lbs (15 kg)
GRAM-60D	3400	GRAML-60D*†	3700	60" (1524 mm)	34 lbs (15 kg)/37 lbs (17 kg)
GRAM-66D	3750	GRAML-66D*†	4050	66" (1676 mm)	37 lbs (17 kg)/40 lbs (18 kg)
GRAM-72D	4150	GRAML-72D*†	4510	72" (1829 mm)	41 lbs (19 kg)/42 lbs (19 kg)
GRAM-84D	4800	GRAML-84D*†	5220	84" (2134 mm)	44 lbs (20 kg)/ 47 lbs (21 kg)
GRAM-96D	5350	GRAML-96D*†	5830	96" (2438 mm)	52 lbs (24 kg) /56 lbs (25 kg)
GRAM-108D*	6000	GRAML-108D*†	6540	108" (2743 mm)	59 lbs (27 kg)/64 lbs (29 kg)
GRAM-120D*	6800	GRAML-120D*†	7400	120" (3048 mm)	66 lbs (30 kg)/72 lbs (33 kg)
GRAM-132D*	7500	GRAML-132D*†	8160	132" (3353 mm)	73 lbs (33 kg)/ 79 lbs (36 kg)
GRAM-144D*	8300	GRAML-144D*†	9020	144" (3658 mm)	80 lbs (36 kg)/ 86 lbs (39 kg)

† Includes Remote Control Enclosure with toggle switch(es) and indicator light(s).

◇ Add 2-8 lbs. (1-3 kg) depending on RMB.

‡ 120 volt models available with RMB only.

† 120/208 and 120/240 volt models available with RMB only.

* 120 volt models not available.

DIMENSIONS

3" (76 mm) Spacer (Standard)

GRAM-D: 18" to 144"W x 15"D x 2.5"H (457-3658 x 381 x 64 mm).

GRAML-D: 18" to 144"W x 15"D x 2.5"H (457-3658 x 381 x 64 mm).

6" (152 mm) Spacer

GRAM-D: 18" to 144"W x 18"D x 2.5"H (457-3658 x 457 x 64 mm).

GRAML-D: 18" to 144"W x 18"D x 2.5"H (457-3658 x 457 x 64 mm).

For special widths, consult factory.

VOLTAGE

120, 208 and 240 volts, single phase. Models with Lights rated 120, 120/208 or 120/240 volts, single phase.

MOUNTING REQUIREMENTS

Recommended Mounting Height: 18"-24" (457-610 mm)

Adjustable Angle Brackets (Provides 1" – 2" (25-51 mm) clearance above Glo-Ray unit)

MINIMUM SPACING –

GLO-RAY MAX WATT DUAL FOODWARMERS May not be installed in combustible surroundings.

Non-Combustible Surfaces: Pass through area: 1" (25 mm) above, 15" (381 mm) to surface below. Corner mount: 3" (76 mm) from non-combustible back wall 15" (381 mm) to surface below.

OPTIONS (NOT FOR RETROFIT)

- Designer Colors: Warm Red, Black, Gray Granite, White Granite, Navy Blue, Hunter Green, Antique Copper
- Gloss Finishes: Smooth White, Gleaming Gold, Glossy Gray, Bold Black, Radiant Red, Brilliant Blue
- Indicator Light
- Tandem Charge (Max. two elements end-to-end)
- Extended Electrical Leads
- Halogen Bulb in lieu of Standard Display Light

- No Bulbs
- Remote Control Enclosure with Toggle Switch, Electronic Infinite Control, Relay, and Indicator Light (In lieu of attached Control Enclosure)
- Non-Adjustable Tubular Stands 18", 20", 22, or 24" (457, 508, 559, or 610 mm) – Available in Designer colors or Gloss finishes
- Bright Annealed Reflector

PRODUCT SPECS

Infrared Foodwarmer

The Infrared Foodwarmer shall be a Glo-Ray®, manufactured by the Hatco Corporation, Milwaukee, WI 53234 U.S.A.

With 24/7 parts and service assistance (U.S. and Canada only), the Foodwarmer shall be a Glo-Ray Model ... , rated at ... watts, ... volts, single phase and be ... millimeters in overall width.

The Glo-Ray shall consist of an aluminum housing and include

as standard equipment adjustable angle brackets, Remote Control Enclosure with toggle switch, Electronic Infinite Control, relay, and indicator light.

The infrared heating element shall be tubular metal sheathed. The foodwarmer shall be factory assembled ready for electrical installation.