



Project _____

Item # _____

Quantity _____

Flav-R-Savor® Portable Holding Cabinets

Models: FSHC-6W1, -6W2
FSHC-7-1, -7-2

The Hatco Flav-R-Savor® Portable Holding Cabinet is capable of holding all types of hot foods at optimum serving temperatures. Thermostatically-controlled heat and humidity allow you to prepare food in advance of peak periods and hold it for hours. Perfect for schools, hospitals, concessions and cafeterias where backup food storage is needed.

Standard features

- FSHC-6W1 and -6W2 units are small enough to fit under normal kitchen counters when ordered with low profile casters
- Tray slides hold food pans on 3" (76 mm) centers or 1.5" (38 mm) centers, and can be removed easily for cleaning
- Accommodates Gastronorm pans
- FSHC-6W1 and -6W2 units have six sets of adjustable angle slides standard (pans not included)
- FSHC-7-1 and -7-2 units have seven sets of adjustable angle slides standard (pans not included)
- Adjustable humidity and temperature controls, digital temperature readout, insulated side walls, field reversible glass doors, large swivel casters with wheel locks, adjustable angle slides and 6' (1829 mm) recessed cord and plug are standard

Pan Capacity

Models FSHC-6W1 and -6W2 include six 18" W x 26" D (457 x 660 mm) sheet pans or six 2/1 Gastronorm pans on 3" (76 mm) centers, eleven 18" W x 26" D (457 x 660 mm) sheet pans[□], eleven 2/1 Gastronorm pans on 1.5" (38 mm) centers[□], or twelve 20" W x 12" D x 2.5" H (508 x 305 x 64 mm) hotel pans[□].

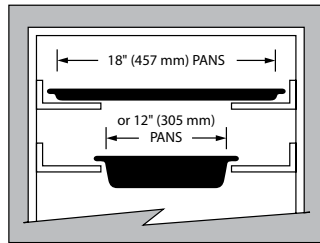

Models FSHC-7-1 and -7-2 include seven 18" W x 26" D (457 x 660 mm) sheet pans on 3" (76 mm) centers, fourteen 18" W x 26" D (457 x 660 mm) sheet pans, on 1.5" (38 mm) centers[□], or seven 20" W x 12" D x 2.5" H (508 x 305 x 64 mm) hotel pans, or seven 1/1 Gastronorm pans.

[□] With purchase of extra pan slides

WATER QUALITY REQUIREMENTS

Water supply in excess of 3.0 grains of hardness per gallon (GPG) (.75 grains of hardness per liter) must be treated and softened before being used. Water containing over 3.0 GPG (.75 GPL) will decrease the efficiency and reduce the operating life of the unit.

Note: Product failure caused by liming or sediment buildup is not covered under warranty.

[□] IFS anti-microbial coatings use naturally-occurring, environmentally sustainable, silver ions to help inhibit the growth of microbes on the powder coated surface. See www.hatcocorp.com/antimicrobial-paint for more information.

For operation, location and safety information, please refer to the Installation and Operating Manual.



Options (available at time of purchase only)

- Side Panels – Non-standard colors are non-returnable
 - Silver Gray standard
 - Designer Black[■]
 - Stainless Steel
- Top – Non-standard colors are non-returnable – Silver Gray standard
 - Designer Black[■]
 - Stainless Steel
- Stainless Steel Door in lieu of glass door
- Heavy-duty Stainless Steel Door with Positive Latch Handle
- Audible Low-Water Alarm (FSHC-7-1, -7-2 models only)
- 2" (51 mm) Low Profile Locking Casters in lieu of Standard Casters (2" [51 mm] diameter with 3" [76 mm] clearance)
- 4" (102 mm) Adjustable Legs in lieu of Standard Casters
- 6" (152 mm) Stainless Steel Legs in lieu of Standard Casters
- Stacking hardware mounted to top of cabinet for two units in lieu of casters – Silver Gray standard
- Bracket for Holding Cord During Transport

Accessories

- Extra Pan Slides
- Wire Shelf (FSHC-7-1, -7-2 models only)



HATCO CORPORATION | P.O. Box 340500 Milwaukee, WI 53234-0500 U.S.A. | (414) 671-6350



www.hatcocorp.com | support@hatcocorp.com | [Find a Hatco Rep](#) | [Image Library](#) | [Document Library](#) | [Patents](#) | [Chat](#)



Flav-R-Savor® Portable Holding Cabinets

Models: FSHC-6W1, -6W2 FSHC-7-1, -7-2

FSHC-6W1, -6W2

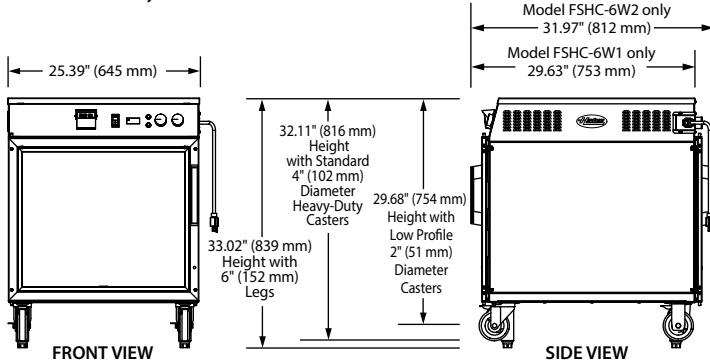

FSHC-7-1, -7-2

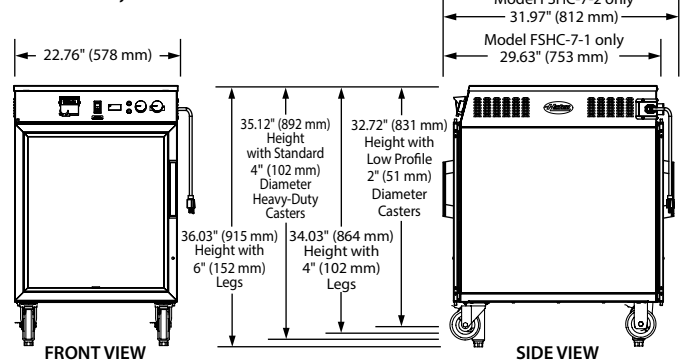

SPECIFICATIONS

Portable Holding Cabinets - Humidified

The shaded areas contain electrical information for International models

Model	Description	Dimensions (W x D x H)	Cabinet Opening (W x H)	Volts	Hertz	Watts	Amps	Plug	Approx. Ship Weight
FSHC-6W1	Single Door with 6 Adjustable Angle Slides	25.39" x 29.63" x 32.11" (645 x 753 x 816 mm) on 4" (102 mm) casters	21.5" x 19" (546 x 482 mm)	120	60	1697	14.1	NEMA 5-15P*	167 lbs. (76 kg)
				220	50	1697	7.7	CEE 7/7 Schuko	
				240	50	1697	7.1	BS-1363 or AS 3112	
				220-230 (CE)	50	1697-1850	7.7-8	CEE 7/7 Schuko	
				230-240 (CE)	50	1562-1697	6.8-7.1	BS-1363	
FSHC-6W2 [†]	Two Doors with 6 Adjustable Angle Slides	25.39" x 31.97" x 32.11" (645 x 812 x 816 mm) on 4" (102 mm) casters	21.5" x 19" (546 x 482 mm)	120	60	1697	14.1	NEMA 5-15P*	180 lbs. (82 kg)
				220	50	1697	7.7	CEE 7/7 Schuko	
				240	50	1697	7.1	BS-1363 or AS 3112	
				220-230 (CE)	50	1697-1850	7.7-8	CEE 7/7 Schuko	
				230-240 (CE)	50	1562-1697	6.8-7.1	BS-1363	
FSHC-7-1	Single Door with 7 Adjustable Angle Slides	22.76" x 29.63" x 35.12" (578 x 753 x 892 mm) on 4" (102 mm) casters	18.5" x 22" (469 x 558 mm)	120	60	1697	14.1	NEMA 5-15P*	175 lbs. (80 kg)
				220	50	1697	7.7	CEE 7/7 Schuko	
				240	50	1697	7.1	BS-1363 or AS 3112	
				220-230 (CE)	50	1697-1850	7.7-8	CEE 7/7 Schuko	
				230-240 (CE)	50	1562-1697	6.8-7.1	BS-1363	
FSHC-7-2 [†]	Two Door with 7 Adjustable Angle Slides	22.76" x 31.97" x 35.12" (578 x 812 x 892 mm) on 4" (102 mm) casters	18.5" x 22" (469 x 558 mm)	120	60	1697	14.1	NEMA 5-15P*	180 lbs. (82 kg)
				220	50	1697	7.7	CEE 7/7 Schuko	
				240	50	1697	7.1	BS-1363 or AS 3112	
				220-230 (CE)	50	1697-1850	7.7-8	CEE 7/7 Schuko	
				230-240 (CE)	50	1562-1697	6.8-7.1	BS-1363	

* Canada, use NEMA 5-20P.

† Two-door pass-through single cabinet, not two units stacked.

WATER CAPACITY

¾ gallon (2.8 liters).

CORD LOCATION

Back of unit, top right side.

PLUG CONFIGURATIONS

NEMA 5-15P

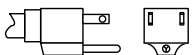

NEMA 5-20P

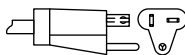

CEE 7/7 Schuko

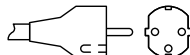

BS-1363

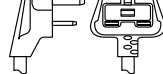

AS 3112

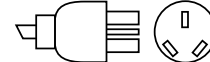

PRODUCT SPECS

Humidified Portable Holding Cabinets

The humidity-controlled heated Portable Holding Cabinet shall be a Flav-R-Savor® Model ... , rated at ... volts, and ... watts, as manufactured by the Hatco Corporation, Milwaukee, WI 53234 U.S.A.

The cabinet shall have ... door(s), tray slides (or holding rack), insulated side walls, 4" (102 mm) swivel casters with wheel locks or 4" (102 mm) legs, and a 6" (152 mm) ...

TOP SURFACE DIMENSIONS

FSHC-6W1, -6W2: 25.39"W x 25.87"D (645 x 657 mm).

FSHC-7-1, -7-2: 22.64"W x 25.87"D (575 x 657 mm).

cord and plug. It shall include a water reservoir, humidity selector switch, temperature selector dial, On/Off switch, and indicating lights.

Accessories shall include sheet pans, extra pan slides, bumper kit, and wire shelf.

Warranty consists of 24/7 parts and service assistance (US and Canada only).

HATCO CORPORATION

P.O. Box 340500 Milwaukee, WI 53234-0500 U.S.A. | (414) 671-6350



www.hatcocorp.com

support@hatcocorp.com

[Find a Hatco Rep](#)

[Image Library](#)

[Document Library](#)

[Patents](#)

[Chat](#)