



Project \_\_\_\_\_

Item # \_\_\_\_\_

Quantity \_\_\_\_\_

# Flav-R-Savor® Tall Dry Holding Cabinets

Models: PFST-1X, -2X, -1XB

Hatco has a profitable way to build sales volume with the Flav-R-Savor® Tall Dry Holding Cabinets. Heat is diffused throughout the cabinet providing gentle, even heat while maintaining optimum serving temperatures. Even after the door is opened and closed, the cabinet temperature quickly recovers so product stays hot.

## Standard features

- Eight-shelf rack, six of which are removable, that can hold up to 16 boxed pizzas or eight bagged pizzas
- Two 60 watt lamps on non-control side
- One- and two-door models come with heavy-duty locking casters for easy portability, tempered glass sides for excellent visibility assuring proper delivery rotation, a temperature control to regulate the heat and a monitor to indicate cabinet temperature
- Available shelf space of 18" (457 mm) square
- PFST-1XB comes with solid back panel, stainless steel inside, with painted Glossy Gray on the outside, an eight-shelf rack with six removable shelves in standard Smooth White, front and side sign holders painted Glossy Gray with flip-up front for access to controls (signs not included), 11" (279 mm) high Designer Black base, latching handle, 4" (102 mm) locking casters, cord and plug



## Options (available at time of purchase only)

Designer Colors (PFST-1XB only)

- Non-standard colors are non-returnable – Glossy Gray standard
- Black



HATCO CORPORATION | P.O. Box 340500 Milwaukee, WI 53234-0500 U.S.A.

(800) 558-0607 | (414) 671-6350 | www.hatcocorp.com | equipsales@hatcocorp.com | intl@hatcocorp.com



# Flav-R-Savor® Tall Dry Holding Cabinets

PFST-1X, -2X, -1XB

**PFST-1X, -2X**

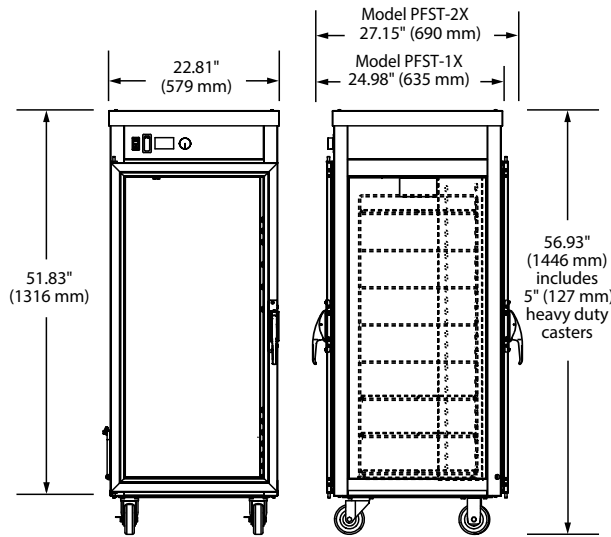

OPERATOR SIDE

RIGHT SIDE

**PFST-1XB**

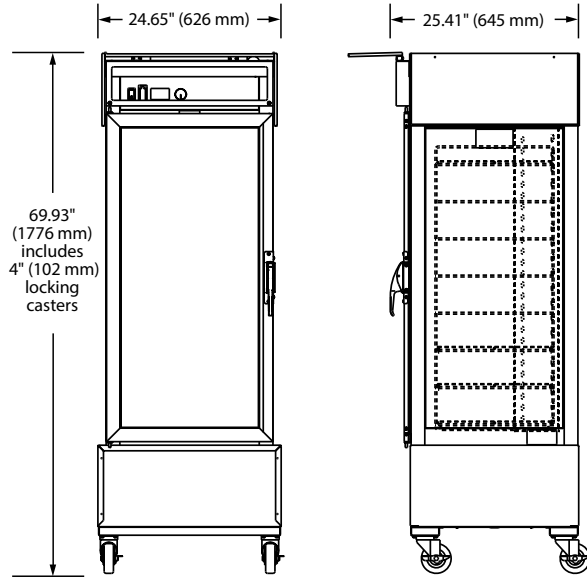

OPERATOR SIDE

RIGHT SIDE

## SPECIFICATIONS Tall Holding Cabinets - Non-Humidified

The shaded areas contain electrical information for International models

Model	Description	Dimensions (W x D x H) with Caster Cart	Cabinet Opening (W x H)	Volts	Watts	Amps	Plug	Ship Weight includes packaging
PFST-1X	1 Door	22.81" x 24.98" x 56.93" (579 x 635 x 1446 mm)	18.75" x 40.37" (476 x 1026 mm)	120	1767	14.7	NEMA 5-15P ▲	200 lbs. (91 kg)
				220	1747	7.9	CEE 7/7 Schuko	200 lbs. (91 kg)
				240	1767	7.4	BS-1363	
PFST-2X	2 Doors	22.81" x 27.15" x 56.93" (579 x 690 x 1446 mm)	18.75" x 40.37" (476 x 1026 mm)	120	1767	14.7	NEMA 5-15P ▲	207 lbs. (94 kg)
				220	1747	7.9	CEE 7/7 Schuko	207 lbs. (94 kg)
				240	1767	7.4	BS-1363	

▲ Canada, use NEMA 5-20P.

## Tall Holding Cabinet with Base - Non-Humidified

Model	Description	Dimensions (W x D x H) with Caster Cart	Cabinet Opening (W x H)	Volts	Watts	Amps	Plug	Ship Weight includes packaging
PFST-1XB	1 Door	24.65" x 25.41" x 69.93" (626 x 645 x 1776 mm)	18.75" x 40.37" (476 x 1026 mm)	120	1767	14.7	NEMA 5-15P ▲	258 lbs. (117 kg)

▲ Canada, use NEMA 5-20P.

## CORD LOCATION

Facing controls, left-hand side panel, bottom right corner.

## PLUG CONFIGURATIONS

NEMA 5-15P

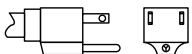

NEMA 5-20P

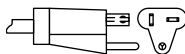

CEE 7/7 Schuko

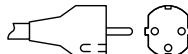

BS-1363

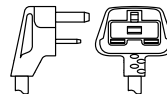

## PRODUCT SPECS

### Flav-R-Savor® Tall Dry Holding Cabinets

The Tall Dry Holding Cabinet shall be a Flav-R-Savor® Model ... rated at ... volts and ... watts, as manufactured by the Hatco Corporation, Milwaukee, WI 53234 U.S.A.

The cabinet shall have ... door(s), tempered glass sides, stationary rack, and

incandescent display lights. It shall include a temperature selector dial, On/Off switch, and indicating lights. A 6' (1829 mm) cord with plug shall be attached.

Warranty consists of 24/7 parts and service assistance (US and Canada only).

**HATCO CORPORATION** | P.O. Box 340500 Milwaukee, WI 53234-0500 U.S.A.

(800) 558-0607 | (414) 671-6350 | www.hatcocorp.com | equipsales@hatcocorp.com | intl@hatcocorp.com