



Project _____

Item # _____

Quantity _____

Flav-R-Savor® Refrigerated Air Curtain Merchandiser

Models: FS3RAC-2726

The Hatco Flav-R-Savor® Air Curtain Merchandiser is the ultimate solution for showcasing fresh, cold products while driving impulse sales. Designed for high-end merchandising, this sleek countertop unit offers easy accessibility and optimal temperature control. With even air distribution and superior product visibility, it not only preserves product freshness but also enhances the appeal of packaged foods and cold beverages — perfect for boosting profits and elevating foodservice offerings.

Standard features

- Product temperature range between 31°F to 41°F (-1°C to 5°C)
- Simple, intuitive digital controls
- 3500K LED lights on the top, front and sides create balanced lighting that highlights food products and beverages
- Includes one adjustable, removable 13" (330 mm) deep shelf that can be positioned flat or slanted
- Doorless design allows for immediate access to products, prevents the spread of germs, and eliminates the need to wipe down handles and doors
- One swing-out, left-hinged rear door (reversible in the field) allows for loading the unit without blocking customer access
- Sleek black textured exterior with insulated glass end panels
- Uses environmentally friendly R-290 refrigerant
- Equipped with 4" (102 mm) legs
- Comes with a 6' (1829 mm) cord and plug



FS3RAC-2726 with optional Sign Holder



FS3RAC-2726 with standard night shade to conserve energy when not in use.

Options (available at time of purchase only)

Housing Color (Interior and exterior) — Black Anodized Standard

Non-standard colors are non-returnable

Gray Granite

Magnetically-attached Sign Holder [Sign dimensions: 23.875"W x 3.5"H x .25"D (606 x 89 x 6 mm)]

IFS anti-microbial coatings use naturally-occurring, environmentally sustainable, silver ions to help inhibit the growth of microbes on the powder coated surface. See www.hatcocorp.com/antimicrobial-paint for more information.

For operation, location and safety information, please refer to the Installation and Operating Manual.



HATCO CORPORATION | P.O. Box 340500 Milwaukee, WI 53234-0500 U.S.A. | (414) 671-6350

www.hatcocorp.com | support@hatcocorp.com | [Find a Hatco Rep](#) | [Image Library](#) | [Document Library](#) | [Patents](#) | [Chat](#)



Flav-R-Savor® Refrigerated Air Curtain Merchandiser

Models: FS3RAC-2726

FS3RAC-2726

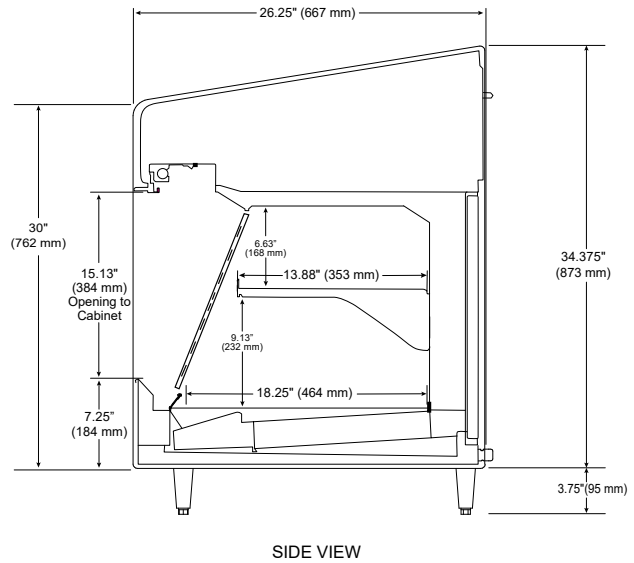
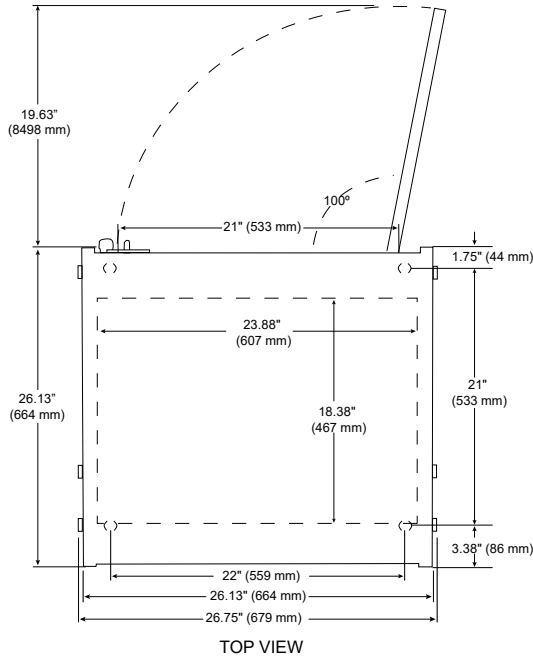

SPECIFICATIONS Flav-R-Savor® Refrigerated Air Curtain Merchandiser

Model	Dimensions (W x D x H) height includes legs	Chamber Height	Volts	Watts	Amps	Plug	Approx. Ship Weight
FS3RAC-2726	26.625" x 26.75" x 38.125" (676 x 679 x 1045 mm)	16.64" (423 mm)	115	9.8	6.0	NEMA 5-15P	220 lbs. (113 kg)

CORD LOCATION
Back of unit bottom left-hand side.

PLUG CONFIGURATIONS
NEMA 5-15P

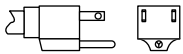

PRODUCT SPECS Flav-R-Savor® Refrigerated Air Curtain Merchandiser

The patented Refrigerated Air Curtain Merchandiser shall be a Flav-R-Savor® model, manufactured by the Hatco Corporation, Milwaukee, WI 53234 U.S.A.
The Refrigerated Air Curtain Merchandiser shall be rated at ... watts, ... volts, and be ... inches (millimeters) in overall width.
It shall consist of a powdercoated steel housing and stainless steel front panel.

No heating elements! The Refrigerated Air Curtain Merchandise features easy-to-use digital controls, an On/Off switch, one swing-out reversible rear door, one standard night shade and a 6' (1829 mm) cord with plug.
Warranty consists of 24/7 parts and service assistance (US and Canada only).

HATCO CORPORATION | P.O. Box 340500 Milwaukee, WI 53234-0500 U.S.A. | (414) 671-6350



www.hatcocorp.com | support@hatcocorp.com | [Find a Hatco Rep](#) | [Image Library](#) | [Document Library](#) | [Patents](#) | [Chat](#)